



Railway Signalling.
Switching the points. Safely and reliably.

Datasheet
Switching Amplifier
Typ: G94/97DC/..

All types

Document number: 6-EL-82247-50-02

Issue date: .05.12.2013

Table of Contents

1	Application	2
2	Types.....	3
3	Power supply	4
4	Inputs	4
5	Typical input signal	5
6	Pulse diagrams	6
6.1	For a duration of an occupation, which is shorter than the interference pulse suppression t_s	6
6.2	For a duration of an occupation, which is shorter than the minimum output pulse duration t_m	6
6.3	For a duration of an occupation, which is longer than the minimum output pulse duration t_m	6
7	Outputs	7
8	insulation voltage	8
9	environmental conditions	8
10	dimension	8
11	Front panel and pin assignment	9

List of abbreviations

Term / Abbreviation	Meaning
DWS (DSS)	Double wheel sensor
SWS (ESS)	Single wheel sensor
ESD	Electro static discharge



This component / module is sensitive to ESD! Handle with care!

When working with electronic components which are sensitive to electrostatically discharges precautionary measures are required: sufficient methods for ESD- protection during transport (conductive and efferent packaging) and handling (electrical grounding and prevention of electric charging) have to be applied and adhered to. Non-profSWsional handling of ESD-sensitive components may lead to damage and voiding the warranty!

1 Application

This unit is used to evaluate the signal of a wheel sensor. It translates the signals from the connected wheel sensor into an electric signal for a downstream system.

Depending on its variant the isolating amplifier can be used to evaluate one double wheel sensor or two single wheel sensors. When it is configured for on double wheel sensor, the error outputs are connected to a signal and error if one occurs in one or both of the two connected system. When configured for a single wheel sensor, only the assigned error output of the system signals the error.

Other variants differ in the type of sensor that can be used or in the minimum output pulse duration or in the pulse suppression of interfering signals:

2 Types

Table 1: Overview

name	order-no.	possible wheel sensor
G94/97DC/01	6-089090	DWS, e.g. 2N59-1R-400RE-40
G94/97DC/02	6-089113	DWS, e.g. 2N59-1R-200-45
G94/97DC/03	6-089155	SWS, e.g. 10 V-types
G94/97DC/04	6-089156	SWS, e.g. N59-1R-200-45
G94/97DC/05	6-089159	DWS, e.g. 2N59-1R-200-45
G94/97DC/06	6-089160	SWS, e.g. N59-1R-200-45

Table 2: Differences

attribute	/01	/02	/03	/04	/05	/06	/07	/08	/09	/10
No-load voltage $U_L = 10\text{ V}$ Current $I_k = 5,0\text{ mA}$	x		x							
No-load voltage $U_L = 8\text{ V}$ Current $I_k = 3,2\text{ mA}$		x		x	x	x				
Omnibus fault message (DWS)	x	x			x					
Separate error output (SWS)			x	x		x				
closed-circuit principle (N/C) only for system outputs	x	x	x	x						
open circuit principle (N/O) only for system outputs					x	x				
Error outputs (N/O)	x	x	x	x	x	x				
equivalent system- and error outputs	x	x	x	x	x	x				
antivalent system- and error outputs										
Interference pulse suppression (t_s):										
• 2 ms										
• 4 ms	x	x	x	x	x	x				
• 8 ms										
• 16 ms										
Minimum output pulse duration (t_m):										
• 0 ms										
• 16 ms	x	x	x	x	x	x				

attribute	/01	/02	/03	/04	/05	/06	/07	/08	/09	/10
Output pulse lengthening (t_v) (for use of AK-outputs only; AZ-outputs = always 0 ms):										
• 0 ms	x	x	x	x	x	x				
• 100 ms										
• 1 s										
• 2,5 s										

3 Power supply

attribute	rated value	note	tolerance [in %]
Voltage range	9 V _{DC} to 60 V _{DC}		--
Amperage drawn @12 V and + 25 °C	80 mA	max.	± 10 %
Amperage drawn @24 V and + 25 °C	50 mA	max.	± 10 %

4 Inputs

A total of 4 inputs (either for 1 DSS using both systems or for a SWS with one system each)

Table 3: 10 V-type

attribute	rated value	note	tolerance [in %]	tolerance [absolute]
No-load voltage (U_L)	10.25 V		± 2.5 %	10.09 V – 10.40 V
Internal resistance (R_i)	2010 Ω	$R_i = \frac{U_L}{I_k} = \frac{10,25 V}{5,0 mA}$	± 5 %	1910 Ω – 2110 Ω
Discrimination threshold (U_U) for an open-circuit	9.953 V	$U_L - 0.047 V$	± 20 %	9.94 V – 9.96 V
Switch-on voltage (U_{on})	8.45 V	$U_L - 1.55 V$	+ 5 % – 1 %	8.39 V – 8.77 V
Switch-off voltage (U_{off})	8.25 V	$U_L - 1.75 V$	+1 % – 5 %	7.94 V – 8.31 V
Response voltage (U_K) for a short-cut	5.04 V	$U_L - 4.96 V$	± 5 %	4.79 V – 5.29 V

Table 4: 8 V-type

attribute	rated value	note	tolerance [in %]	tolerance [absolute]
No-load voltage (U_L)	8.16 V		± 2.5 %	8.04 V – 8.28 V

attribute	rated value	note	tolerance [in %]	tolerance [absolute]
Internal resistance (R_i)	2550 Ω	$R_i = \frac{U_L}{I_k} = \frac{8.16 V}{3.2 mA}$	$\pm 5 \%$	2423 Ω – 2678 Ω
Discrimination threshold (U_U) for an open-circuit	7.953 V	$U_L - 0.047 V$	$\pm 20 \%$	7.94 V – 7.96 V
Switch-on voltage (U_{on})	6.45 V	$U_L - 1.55 V$	+ 5 % – 1 %	6.38 V – 6.77 V
Switch-off voltage (U_{off})	6.25 V	$U_L - 1.75 V$	+1 % – 5 %	5.94 V – 6.31 V
Response voltage (U_K) for a short-cut	2.25 V	$U_L - 5.75 V$	$\pm 5 \%$	2.13 V – 2.37 V

5 Typical input signal



The voltages noted refer to a measuring point at the end of the wire of the wheel sensor at the connection to the switching amplifier neglecting any impedance of the wires.

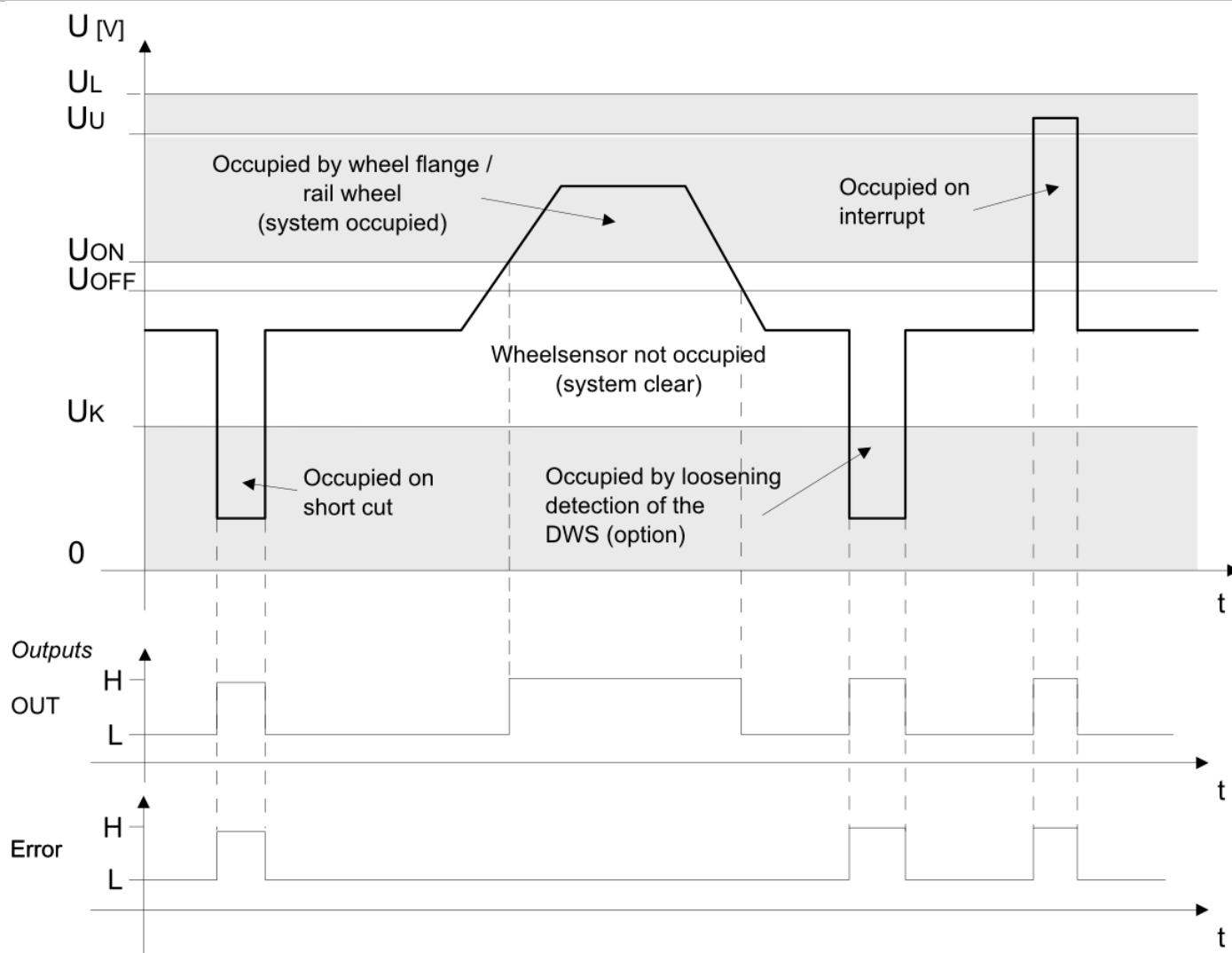

6 Pulse diagrams

6.1 For a duration of an occupation, which is shorter than the interference pulse suppression t_s

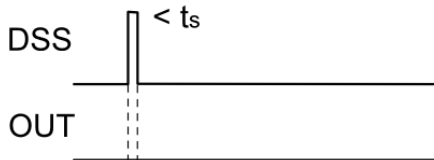

The diagrams are not scaled!

Conclusion: The OUT output is inactive

6.2 For a duration of an occupation, which is shorter than the minimum output pulse duration t_m

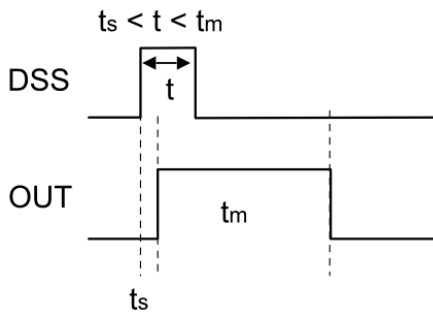

The diagrams are not scaled!

Conclusion: The OUT output is extended up to the minimum output pulse duration t_m , in addition to the opto-coupler switch on delay (equal to t_s).

In addition, depending on the types, it is possible to lengthen the output by $t_v \rightarrow$ then $t_m + t_v$.

6.3 For a duration of an occupation, which is longer than the minimum output pulse duration t_m

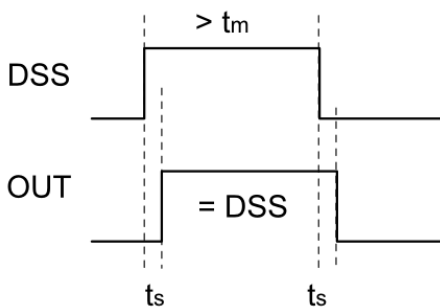

The diagrams are not scaled!

Conclusion: The OUT output is after the opto-coupler switch on delay (equal to t_s) as long as the input pulse.

In addition, depending on the types, it is possible to lengthen the output by $t_v \rightarrow$ then $t_m + t_v$.

7 Outputs

Outputs per DWS:

- 4 opto-coupler pulse outputs (2*OUT per DWS-system)
- 4 opto-coupler error outputs (combined, internally as omnibus fault message)

Ausgänge je SWS:

- 4 opto-coupler pulse outputs (2*OUT per SWS)
- 4 opto-coupler error outputs (2*ERR per SWS)

Attribute	rated value	note	tolerance [in %]	Tolerance [absolute]
Current on contact	< 100 mA	Leakage current $I_{Leck} < 50 \mu A$ in locked status		
Voltage on contact	< 100 V _{DC}			
Voltage drop	< 1,1 V	@ 100 mA		
Galvanic isolation		Between input, output and power supply		
Interference pulse suppression t_s	2,0 ms 4,0 ms 8,0 ms 16,0 ms	Depends on type (→ Table 2: Differences)	± 5 %	1,9 ms – 2,1 ms 3,8 ms – 4,2 ms 7,6 ms – 8,4 ms 15,2 ms – 16,8 ms
Minimum output pulse duration @ OUT-output t_m	0,0 ms 16,0 ms		± 5 %	0 ms 15,2 ms – 16,8 ms
Output pulse lengthening t_v	0,0 ms 100,0 ms 1,0 s 2,5 s		± 5 %	0 ms – 2 ms 95,0 ms – 105,0 ms 0,95 s – 1,05 s 2,38 s – 2,63 s
Well-defined output signal after				
• Switching on U_{IN}	< 1,3 sec.			
• Switching off U_{IN}	< 100 ms			
Simulation-Button		• per Sensor-system: 1 Button		
LEDs		<ul style="list-style-type: none"> • per Sensor-system: 1 yellow LED for occupied • per Sensor-system: 1 red LED for error 		



N/O-outputs (system- / error outputs in working principle) are always inactive at power loss.
 N/C-outputs (system- / error outputs in current principle) are changing at power loss to N/O.

8 insulation voltage

Attribute	Rated value
input SWS 1 to input SWS 2	2,5 kV
input DWS / SWS 1 / SWS 2 to output	2,5 kV
input DWS / SWS 1 / SWS 2 to power-supply U_{IN}	2,5 kV
Power supply U_{IN} to output	2,5 kV

9 environmental conditions

Attribute	Rated valued		
Temperature range	- 25 °C to + 70 °C [-13°F to 158°F] (climate class T1 according to DIN EN 50125-3) - 40 °C to + 80 °C [-40 F to 176 F] (function verified)		
Humidity exposure	< 98 % rel. Humidity (climate class T1 according to DIN EN 50125-3)		
Contamination level to which isolation is guaranteed	PD 2 (according to DIN EN 50124-1)		
mechanical – vibration	Vibration according to DIN EN 50125-3 (1 – 3 m distance from track)		
	Frequency-range: 5 Hz – 2000 Hz	Amplitude: 5 Hz; 0,002 g ² /Hz 600 Hz;0,000011 g ² /Hz 2000 Hz;0,000011 g ² /Hz	Test-duration: 100 min/axis, in 3 axis
Mechanical – shocks	shocks according to DIN EN 50125-3		
	Shock-form: Half sinusoidal	Amplitude: 2 g, 11 ms	No. of shocks: 100 shocks in both main direction of the 3 perpendicular main axis.

10 dimension

Attribute	Rated value	Note
WxHxD	22x100x113	
Din-Rail mount	Clamp	with spring and metal holder

11 Front panel and pin assignment

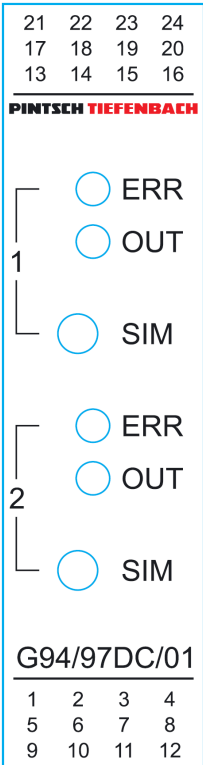
Front panel			Pin assignment																												
 <table border="1" style="font-size: small;"> <tr><td>21</td><td>22</td><td>23</td><td>24</td></tr> <tr><td>17</td><td>18</td><td>19</td><td>20</td></tr> <tr><td>13</td><td>14</td><td>15</td><td>16</td></tr> </table>  <p style="font-size: x-small;">G94/97DC/01</p> <table border="1" style="font-size: x-small;"> <tr><td>1</td><td>2</td><td>3</td><td>4</td></tr> <tr><td>5</td><td>6</td><td>7</td><td>8</td></tr> <tr><td>9</td><td>10</td><td>11</td><td>12</td></tr> </table>	21	22	23	24	17	18	19	20	13	14	15	16	1	2	3	4	5	6	7	8	9	10	11	12	LED OUT	DWS-system I or II: occupied	no.	name	description	note	plug / socket
	21	22	23	24																											
	17	18	19	20																											
	13	14	15	16																											
	1	2	3	4																											
	5	6	7	8																											
	9	10	11	12																											
				1-4	VCC	Power supply	Connected internally	No.1																							
				5-8	GND	Power supply	Connected internally	No. 2																							
				9	In 1 +	DWS-System I input	Brown	No. 3																							
				10	In 1 -		Yellow																								
				11	In 2 +	DWS-System II input	Green																								
				12	In 2 -		White																								
	LED ERR	DWS-system I or II: Error		13	OUT 1.I	output 1, system I	System outputs	No. 4																							
				14	OUT 1.II	output 1, system II																									
				15	OUT 2.I	output 2, system I																									
				16	OUT 2.II	output 2, system II																									
	Button SIM	DWS-system I or II: Buttons for simulation		17	ERR 1.I	error 1, system I	Error outputs	No. 5																							
				18	ERR 1.II	error 1, system II																									
				19	ERR 2.I	error 2, system I																									
				20	ERR 2.II	error 2, system II																									
				21	V+ 1.I	For OUT1.I and ERR 1.I	Power supply for output opto- coupler: 12 to 24 V _{DC}	No. 6																							
				22	V+ 1.II	For OUT1.II and ERR 1.II																									
				23	V+ 2.I	For OUT2.I and ERR2.I																									
24				V+ 2.II	For OUT2.II and ERR2.II																										



Coding for plugs and sockets:

Plug: No. 1 → 1+3, No. 2 → 6+8, No. 3 → 9+12, No. 4 → 13+14, No. 5 → 18+19, No. 6 → 23+24

Socket: No. 1 → 2+4, No. 2 → 5+7, No. 3 → 10+11, No. 4 → 15+16, No. 5 → 17+20, No. 6 → 21+22



Document number: 6-EL-82247-50-02

PINTSCH TIEFENBACH GmbH
Beisenbruchstr. 10
D-45549 Spockhövel

Phone +49 (0) 2324/705-4
Fax +49 (0) 2324/705-114

www.pintschtiefenbach.de
info@pintschtiefenbach.de

PINTSCH TIEFENBACH
A Schaltbau company